



USER & INSTALLATION MANUAL WP-GI 16 & 32A



Whisper Power Galvanic Isolation Blocker



GALVANIC ISOLATION BLOCKER Installation Instructions for 16 or 32 amps

General Instruction

Thanks for choosing our product. This manual contains important safety and operation instructions. Read this manual before use. The WP-GI needs to be installed by a professional installer.

Introduction

In order to meet the current standard CE (ENISO 13297), the ground wire of the shore power installation must be connected to the ship's mass. The ship's mass is again connected to the hull, fuel tank, engine, propeller and propeller shaft, zinc anodes, etc. Because your ship is grounded, the earth leakage circuit breaker will jump. This ensures a safe situation on board. However, this advantage has also a disadvantage. Since all ships are now connected by the shore earth, galvanic action between ships and shore arises. This is because ships and shore embankments are made of different metals. As is well known, there are potential differences between different metals. To eliminate this potential difference again is called a galvanic isolation blocker between the shore and the ship earth placed. The galvanic isolation blocker provides a threshold voltage of approximately 1 Volt. Because the galvanic isolation blocker is placed between the earth connection, a solid construction is of vital importance! Therefore, the galvanic isolation blocker is capable of handling a very high current at an earth fault. Especially when a low weight is desired, the galvanic isolation blocker is preferred over the isolation transformer. An isolation transformer gives the same result as a galvanic isolation blocker. The Galvanic isolation blocker is constructed of anodized aluminum heat sink and electrical connections are made of high quality material. The electronic circuitry is potted making it even under extreme conditions can do its job and requires no further maintenance.

Safety Instruction

As dangerous voltages and high temperature exists within the WP-GI, only qualified and authorized maintenance personnel are permitted to install and test it.

This manual contains information concerning the installation and operation of the WP-GI. All relevant parts of the manual should be read prior to commencing the installation. Please follow the local regulations.

Any operation against the safety requirement or against design, manufacture and safety standard are out of the manufacturer warranty.

The galvanic isolation blocker is connected between the internal grounding system on your boat and the ground lead of the shore power cable(s). This connection is important for safety considerations and you should not attempt this installation unless you understand the circuit and are competent in this type of electrical work. Although highly reliable, it should be tested once per season, and re-tested after a condition that may have influenced it, such as a lightning strike in the vicinity, or an on-board electrical short that either caused a circuit breaker or fuse to blow or used the ground for the neutral conductor.

General Precautions

- Do not expose the WP-GI to dust, rain, snow, liquids or gases of any type, it is designed for indoor use only in a well ventilated area.

- For safety purposes, the product should be installed in a heat-resistant environment. Avoid the presence of e.g. chemicals, synthetic components, curtains or other textiles in the immediate vicinity of the product. Please do not put any inflammable goods near to WP-GI
- Keep a clear space of 10 cm around the product for ventilation.
- The galvanic isolation blocker must be mounted with its length vertical to allow for maximum cooling. Under normal circumstances, the temperature increase of the heat sink is not more than 20°C. However the unit may become hot when conducting fault ground current.
- DO NOT block ventilation, otherwise the WP-GI may overheat.
- To avoid fire and electric shock make sure all cables have the correct thickness and are connected well.
- Connections and safety features must be according to the locally applicable regulations.
- Never place unit directly above batteries; gases from a battery will corrode and damage the WP-GI.
- Wire the galvanic isolation blocker into the green (safety) grounding conducting connection as shown below.

Warning!



The galvanic isolation blocker must be wired into the green (safety) grounding conducting connection ahead of all grounding connections to the vessel such that no ground connections on the vessel bypass the galvanic isolation blocker making it ineffective.

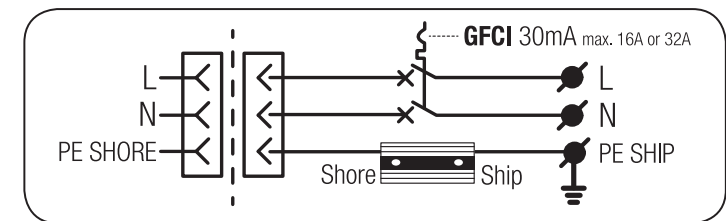

Testing

Testing should be done only by authorized engineers. Remove the AC shore connection. There are two ways for a galvanic isolation blocker to fail either the diodes are shorted, or they are blown open. You can test them with a multi meter with diode meter. At any time, with the voltmeter on the DC range, put it across the shore power side to the boat side of the isolator. There should always be measured 0,9 Volt.

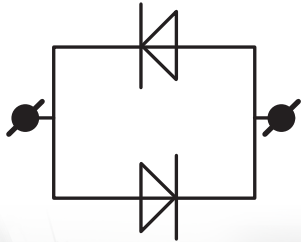

Datasheet



	WP-GI Galvanic Isolation Blocker 16A	WP-GI Galvanic Isolation Blocker 32A
	60110140	60110150
GENERAL SPECIFICATIONS		
Maximum current	16A	32A
Peak current	1600A / 20ms	3000A / 20ms
Voltage	85V – 260V AC	85V – 260V AC
Connection	2 x M6 studs	2 x M6 studs
Heat sink	Anodized aluminium	Anodized aluminium
IP category	IP 67 (Waterproof potted)	IP 67 (Waterproof potted)
Weight	1,2 kg	2,54 kg
Dimensions (hwxwd)	60 x 120 x 200mm	63 x 164 x 235mm
Tested in accordance with	ANSI/ABYC A-28	ANSI/ABYC A-28

CE declaration of conformity

We,
Whisper Power B.V.
Kelvinlaan 82 • 9207 JB Drachten
The Netherlands

hereby declare that:

Product:
60110140 WP-GI 16A and
60110150 WP-GI 32A

Product type: Galvanic Isolation Blocker

Is in conformity with the following provisions of the EC 2004/108/EC (EMC directive) and the 2006/95/EC (Safety directive).

The following standards have been applied:

- Generic emission standard: EN61000-6-3:2007
- Generic immunity standard: EN61000-6-1:2007
- Low voltage standard: EN60950-1:2006

Drachten,

R.ter Heide
C.E.O. Whisper Power B.V.



WP-GI Galvanic Isolation Blocker 16A

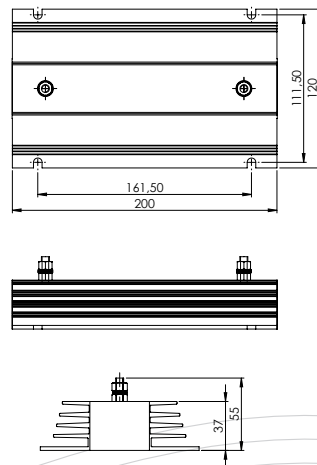

WP-GI Galvanic Isolation Blocker 32A

