



SIMARINE®



## SC303 & SC503

USERS MANUAL

V1.3

|  |          |
|--|----------|
| <b>1. Introduction</b>                                   | <b>3</b> |
| <b>2. Safety</b>   | <b>3</b> |
| <b>3. Overview</b>                                       | <b>4</b> |
| <b>4. Installation</b>                                   | <b>4</b> |
| <b>4.1 Cables</b>  | <b>4</b> |
| 4.1.1 Power cable  | 5        |
| <b>5. Connecting</b>                                     | <b>5</b> |
| 5.1 SCX03 installed on the minus terminal of the battery | 6        |
| <b>6. Technical specifications SC303 &amp; SC503</b>     | <b>6</b> |
| <b>7. Troubleshooting</b>                                | <b>8</b> |
| 7.1 Negative current values                              | 8        |
| 7.2 Shunt is not visible on PICO                         | 8        |

## 1. Introduction

Simarine's high precision SCX03 (SC303 & SC503) active digital shunt measures voltage, current and temperature of the battery or battery bank.

It can be used for monitoring current draw of heavy consumers (inverters, bow and stern thrusters, anchor winches) and current generators (shore power chargers and solar panels). Additionally, it allows monitoring tanks for fuel, fresh and grey water.

- Innovative combination of shunt and tank level module. **SC303** is an active combo shunt for PICO battery monitor with 2x voltages, 2x tank level or temperature, 1x socket for temperature sensor with JST connector and 1x current sensor up to 300A for up to 75V systems. It can be used for monitoring current draw of heavy consumers (inverters, bow and stern thrusters, anchor winches) and current generators (shore power chargers and solar panels). Additionally, it allows monitoring tanks for fuel, fresh and grey water. SC303 is capable of measuring continuous current up to 300 A and suitable for maximal power of 3600 W at 12 V or 7200 W at 24 V
- Innovative combination of shunt and tank level module. **SC503** is a high precision combo shunt for PICO battery monitor with 2x voltage, 2x temperature, 1x socket for temperature sensor with JST connector and 1x current sensor up to 500A for up to 75V systems. SC503 is capable of measuring continuous current up to 500 A and suitable for maximal power of 6000 W at 12 V or 12000 W at 24 V.

## 2. Safety

Electrical specialists with proper safety equipment should make installation of Simarine electronics. When working with batteries, you should wear protective clothing and eye protection.

**CAUTION:** Batteries contain acid, a corrosive, colorless liquid that will burn your eyes, skin, and clothing. Should the acid come in contact with eyes, skin or clothing, wash it immediately with soap under fresh water for at least 15 minutes, and seek medical support immediately.

**CAUTION:** Do NOT connect anything to a damaged battery. It could heat up, catch fire or explode.

**CAUTION:** Lead-acid batteries can generate explosive gases during operation. Never smoke, allow flames or sparks near the battery. Make sure to keep sufficient ventilation around the battery.

### 3. Overview

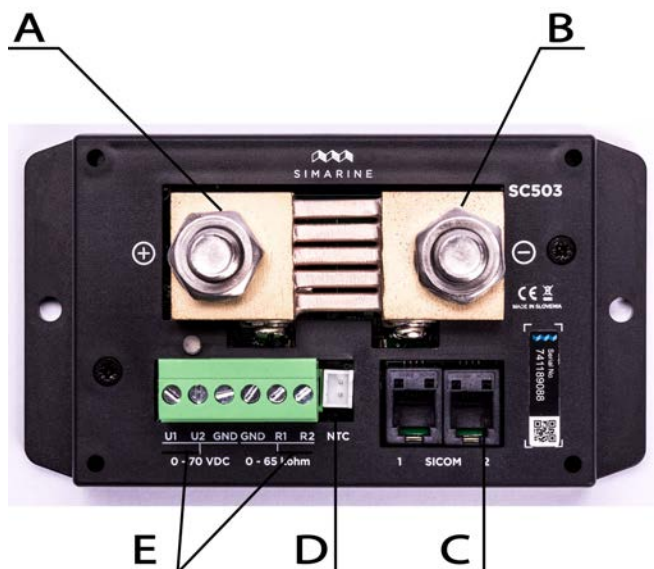

- A - Battery
- B - Hub - GND
- C - 2x SiCOM port
- D - 1x JST socket for temperature sensor
- E - 2x Voltage & 2x Resistance input

### 4. Installation

**CAUTION:** install the shunt module in a clean dry place, protected from accidental spilling of liquids.

- Remove the shunt cover by unscrewing four screws on top of the shunt cover. To install the shunt use the supplied voltage cables find a place no further than 3 m away from the battery/battery bank. You can fix the shunt with the supplied screws using two holes on bottom of the casing.
- Connect all cables
- Place back the shunt cover and screw the four screws on the cover of the shunt unit.

#### 4.1 Cables

For the SiCOM connection use the supplied cable. If not possible, use the following table to determinate the right cable type.

| CABLES       |   |
|--------------|---|
| Cable length | Cable type  |
| < 5m         | No limitations                                      |
| >= 5m        | 2x2x0.25 mm <sup>2</sup> Twisted pair (recommended) |

### 4.1.1 Power cable

Minimum power cable cross-section requirement at maximal temperature of insulation 70 °C (160 °F).

| Continuous current | Area                |
|--------------------|---------------------|
| 500 A              | 220 mm <sup>2</sup> |
| 400 A              | 150 mm <sup>2</sup> |
| 300 A              | 95 mm <sup>2</sup>  |
| 200 A              | 50 mm <sup>2</sup>  |
| 100 A              | 25 mm <sup>2</sup>  |

**CAUTION:** Failure to observe the required cable cross-section can damage the shunt, wiring, or cause a fire.

## 5. Connecting

For proper function of Simarine's SC303/SC503 digital shunt **it is necessary to take the following steps:**

1. Disconnect the battery/battery bank plus and minus terminal, for safety reason.
2. Connect the shunt to Simarine's PICO via the SICOM port.
3. Connect shunt voltage sensing input to a battery terminal.
4. Connect the temperature sensor to the shunt and place it near the battery/battery bank (optional)
5. Connect batteries/batteries bank minus or plus terminal through the shunts IN terminal.
6. Connect all consumers and charging sources to the OUT terminal on the shunt.

Each correctly connected shunt needs to be configured. This is done via PICO in an easy way. The configuration process is described in PICO's manual.

- PICO manual & other user manuals: <https://simarine.net/manuals>

It is recommended that the shunt is installed in the negative line if possible.

**CAUTION:** After connecting the shunt, make sure that all the connections between cables and shunt are tight. Loose connections may cause sparks, heating and even a fire. It may also damage the shunt.

## 5.1 SCX03 installed on the minus terminal of the battery

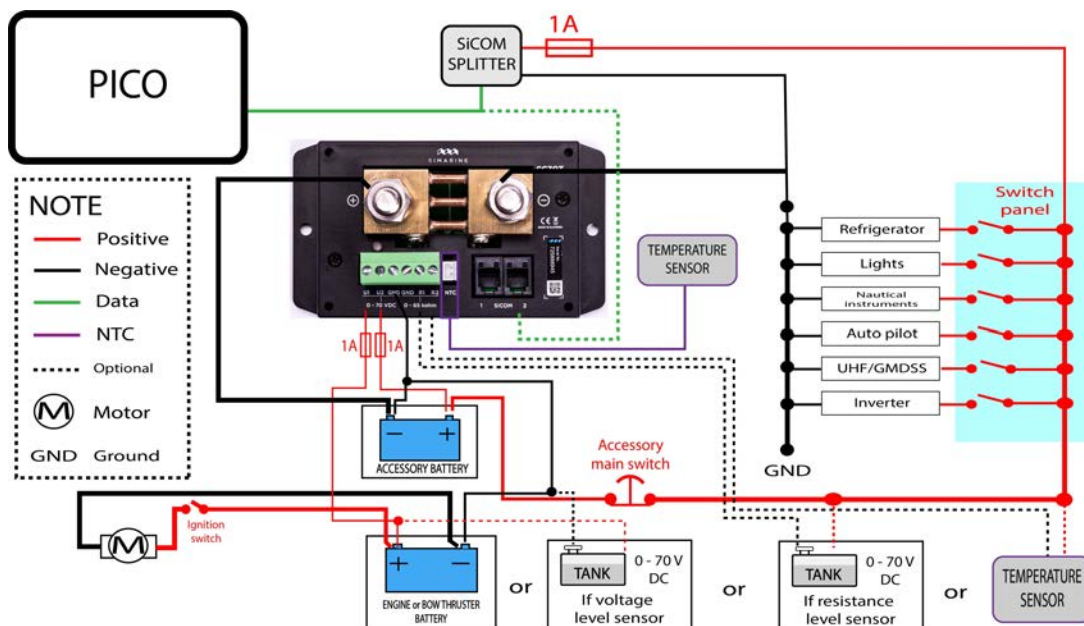

## 6. Technical specifications SC303 & SC503

| SC303                          |                          |
|--------------------------------|--------------------------|
| Operating Voltage range        | 6 – 35 V                 |
| Temperature range              | -20 – 70°C (-4 – 158 °F) |
| Power consumption at 12V       |                          |
| Operating                      | 0.8 mA                   |
| Current Measuring range        |                          |
| Per channel                    | 0.01 - 320 A             |
| Accuracy                       | ± 0.6 %                  |
| Resolution                     | 0.01 A                   |
| Sampling rate                  | 100 ms                   |
| Maximal current                |                          |
| Continuous                     | 300 A                    |
| Peak current (<1min)           | 700 A                    |
| Peak current (<5min)           | 400 A                    |
| Voltage drop at 300 A          | 50 mA                    |
| Maximal voltage on connections | 35 V                     |
| Voltage inputs                 |                          |
| Range                          | 0 - 75 V                 |
| Accuracy                       | ± 0.2 %                  |
| Resolution                     | 1 mV                     |
| Sampling rate                  | 100 ms                   |

|                                     |  |
|-------------------------------------|--|
| <b>Resistance inputs</b>            |  |
| Range                               | 0 Ohm - 65 kOhm                            |
| Accuracy                            | ± 3 %                                      |
| <b>Temperature sensor - NTC 10k</b> |  |
| Range                               | -15 - +80 °C                               |
| Accuracy (-10 - 60 °C, 14 - 140 °F) | ± 3%                                       |
| Connectivity                        | Up to                                      |
| Batteries                           | 1  |
| Temperature sensors                 | 3  |
| Voltage sensors                     | 2  |
| SiCOM RJ9 Sockets                   | 2  |
| <b>Installation and Dimensions</b>  |  |
| Dimensions                          | 120 x 120 x 60 mm<br>4.72 x 4.72 x 2.36 in |
| Battery connection                  | M 10 bolts                                 |

|                                     |  |
|-------------------------------------|--|
| <b>SC503</b>                        |  |
| <b>Operating</b>                    |  |
| Voltage range                       | 6 - 35 V                                   |
| Temperature range                   | -20 - 70°C (-4 - 158 °F)                   |
| <b>Power consumption at 12V</b>     |  |
| Operating                           | 1.2 mA                                     |
| <b>Current Measuring range</b>      |  |
| Per channel                         | 0.01 - 700 A                               |
| Accuracy                            | ± 0.6 %                                    |
| Resolution                          | 0.01 A                                     |
| Sampling rate                       | 100 ms                                     |
| <b>Maximal current</b>              |  |
| Continuous                          | 500 A                                      |
| Peak current (<1min)                | 1000 A                                     |
| Peak current (<5min)                | 700 A                                      |
| Voltage drop at 300 A               | 50 mA                                      |
| Maximal voltage on connections      | 35 V                                       |
| <b>Voltage inputs</b>               |  |
| Range                               | 0 - 75 V                                   |
| Accuracy                            | ± 0.2 %                                    |
| Resolution                          | 1 mV                                       |
| Sampling rate                       | 100 ms                                     |
| <b>Resistance inputs</b>            |  |
| Range                               | 0 Ohm - 65 kOhm                            |
| Accuracy                            | ± 3 %                                      |
| <b>Temperature sensor - NTC 10k</b> |  |
| Range                               | -15 - +80 °C                               |
| Accuracy (-10 - 60 °C, 14 - 140 °F) | ± 3%                                       |
| Connectivity                        | Up to                                      |
| Batteries                           | 1  |
| Temperature sensors                 | 3  |
| Voltage sensors                     | 2  |
| SiCOM RJ9 Sockets                   | 2  |
| <b>Installation and Dimensions</b>  |  |
| Dimensions                          | 120 x 120 x 60 mm<br>4.72 x 4.72 x 2.36 in |
| Battery connection                  | M 10 bolts                                 |

## 7. Troubleshooting

### 7.1 Negative current values

---

If PICO is showing the wrong sign for current value, check if the shunt is correctly installed. This means the battery/battery bank minus (optionally plus) terminal is connected to the IN terminal on the shunt. If this is not the case, you can **reinstall** the shunt or simply **switch** the IN and OUT terminal via the shunt configuration on PICO.

### 7.2 Shunt is not visible on PICO

---

If the shunt is not visible on PICO's menu, check the following:

- Is the shunt properly connected via the SiCOM port to the PICO
- If you are using your own SiCOM cable make sure it has the right square and is twisted.
- Check if the voltage sensing input is correctly installed and doesn't have the plus and minus terminal switched